

**AV** *Supply Group*

# CATALOGUE



# About

## AV Supply Group – Your Trusted Source for AV Solutions Across New Zealand & Australia

AV Supply Group provides innovative audiovisual technology tailored to the needs of businesses, schools, and professionals.

Our comprehensive catalogue features high-quality products from trusted brands—ranging from display mounts and networking to conferencing systems and concealment solutions—carefully selected to support seamless performance and collaboration in residential & commercial applications.



Proudly operating in both New Zealand and Australia, we're committed to delivering expert advice, reliable service, and fast nationwide shipping.

Whether you're upgrading a boardroom, fitting out a classroom, or designing a custom AV system, AV Supply is your go-to partner for future-ready AV solutions.

*Browse our catalogue and experience quality you can depend on.*



# content

About

Content

AV Accessories

Cables & Connectivity

Conferencing Solutions

Display Solutions

Display Mount Solutions - Residential

Display Mount Solutions - Commercial

Furniture Solutions

Motorised Mount Solutions

Projection Solutions

Racking Solutions

Networking Solutions

Contact Details

**AV** Supply Group Ltd

# AV Accessories



**SANUS**<sup>®</sup>  
A brand of **legrand**

**CHIEF**<sup>®</sup>  
A brand of **legrand**

Complete your setup with our premium range of AV accessories—designed to support, protect, and enhance your audiovisual systems.

Ideal for home, office, and commercial installations, our accessories combine durability, compatibility, and clean design to suit any project.

# AFBB

## Brush Wall Faceplate



A brush wall plate is the ideal solution for easily passing cables through walls. Either attached to a standard electrical backing box or screwed directly to the wall, a brush plate means no unnecessary cable terminations, saving both time and money.

### Features:

- Standard 2 Gang electrical box
- AV Wallplate Brush Style
- Screws included
- Available in white and black

# SA405

## Universal Soundbar Mount



The SA405 is compatible with most TV wall mounts and many soundbars, and is easy to assemble with all hardware included and no additional drilling into the wall needed.

Perfect for use with any mount.

### Features:

- Supports up to 6.8kg
- Attaches to bottom of TV mount
- No additional drilling required
- All hardware included
- 10 Year Warranty

Installation Manual



Technical Drawing



# WSBWM1-B2

## Universal Extendable Soundbar Wall Mount



### Features:

- Features an extendable design allowing for easy depth adjustment 5.65" for optimal audio performance for Dolby Atmos soundbars
- Easily mount the your soundbar directly to drywall, wood studs or concrete giving you the flexibility to center below your TV
- Easily access power and manage cables directly to the wall behind the soundbar
- Featuring a slim profile, the SANUS soundbar wall mount stays hidden creating a completely seamless, floating look on the wall
- In just 15-minutes and 3-steps your soundbar will be secure on the wall, all the hardware needed for installation is included in the box

Installation Manual



Technical Drawing



# PAC525/526FCW

## Large in wall storage box



The PAC526F simplifies flat panel installation by providing an organized, recessed space for routing excess cables and for attaching surge protectors/power conditioners.

### Features:

- Hides all cables, surge protectors, streaming boxes etc
- Can be installed pre or post-construction
- Mounts in landscape or portrait orientation
- Works with drywall and stud walls
- Zip tied anchor points inside for clean cable management
- Holds up to 4.5kg of equipment
- UL Listed & Safety Certified
- 10 Year Warranty

Installation Manual











Technical Drawing

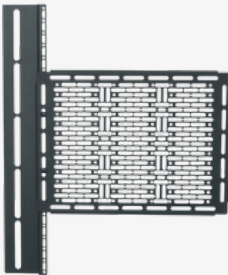

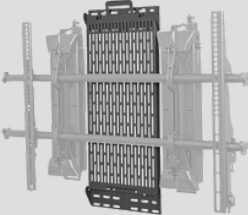
# FUSION SERIES ACCESSORIES

## Hardware Storage Solutions

Image	SKU	Features	Datasheet
	CSSLP15X10	<ul style="list-style-type: none"> <li>• Concealed behind display component storage</li> <li>• Push to open/close mechanism</li> <li>• Universal small device mounting pattern</li> <li>• Flexible mounting orientation and placement</li> <li>• 6.8kg weight rating</li> </ul>	
	CSMP9X12	<ul style="list-style-type: none"> <li>• Discreet behind display storage</li> <li>• universal compatibility and orientation</li> <li>• Low profile design</li> <li>• 4.5kg weight rating</li> </ul>	
	CSPR	<ul style="list-style-type: none"> <li>• Installs behind or along any wall mount or display</li> <li>• Removable for component service without moving the display</li> <li>• Handle helps ease of transport, installation and removal of plate</li> <li>• Security locking mechanism</li> </ul>	
	CSPH	<ul style="list-style-type: none"> <li>• Hinges 90° for ease of access to components</li> <li>• Security locking screws</li> <li>• Handle for ease of transport, install and maneuvering of panel</li> <li>• Modular sizing for efficient use of product</li> </ul>	

# FUSION SERIES ACCESSORIES

## Shelf & Speaker Mounts

Image	SKU	Features	Datasheet
	FCA810	<ul style="list-style-type: none"> <li>• 203 mm wide shelf sits above or below display to hold AV components</li> <li>• Lip on end of shelf prevents components from sliding off</li> <li>• Extension range 457 – 782 mm</li> <li>• Height adjustable for 62" to 100" displays</li> <li>• TAA Compliant</li> </ul>	
	FCA840	<ul style="list-style-type: none"> <li>• Supports mounting speakers center of display</li> <li>• Expandable to accommodate various display sizes</li> <li>• Universal design accommodates most speaker brands</li> <li>• Low-profile design does not add depth to installation</li> <li>• Typical Screen Size: 70" - 100" (1778mm - 2540mm)</li> <li>• Weight Capacity: 9.1 kg</li> </ul>	
	FCA841	<ul style="list-style-type: none"> <li>• Supports mounting speakers on the side of the display</li> <li>• Wall mounts: 1137.9mm-2153.9mm</li> <li>• Ceiling/cart: 1173.5mm-1971.0mm</li> </ul>	

\*Compatible with Chief Fusion Series Wall, Ceiling and Cart solutions

**AV** Supply Group Ltd

# Conferencing Solutions



**MAXHUB**



Find reliable Unified Communications & Conferencing (UCC) tools to make meetings more efficient and engaging—whether in the boardroom, classroom, or remote workspace.

The range includes videobars, speakerphones, microphones, cameras, and interactive displays designed for smooth integration with popular platforms like Zoom and Microsoft Teams.

# U50

## Plug-and-Play Microsoft Teams USB videobar

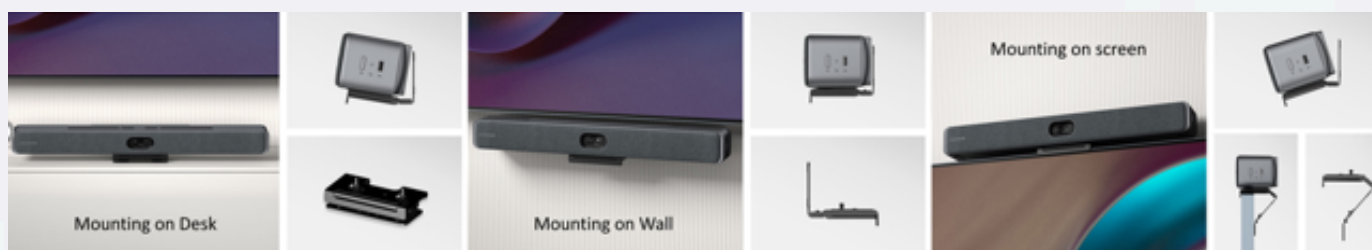

The XBar U50 is a USB mode dual-camera Videobar designed for small to medium sized rooms and BYOD scenarios. With 100MP dual cameras, 12 beam-forming microphones, AI-enhanced audio, and FlexMount for easy installation, it offers plug-and-play conferencing without fixed systems for ultimate flexibility.

### Features:

- 125deg FOV
- 100MP Dual-Lens Camera System
- Automatic Privacy Shutter
- 12 MEMS Microphone Array with 8m pick up range
- Dual 15W Speakers
- FlexMount included for easy installation

Quick Start Up Guide



Datasheet



# V50

## All-in-one Android-based Videobar

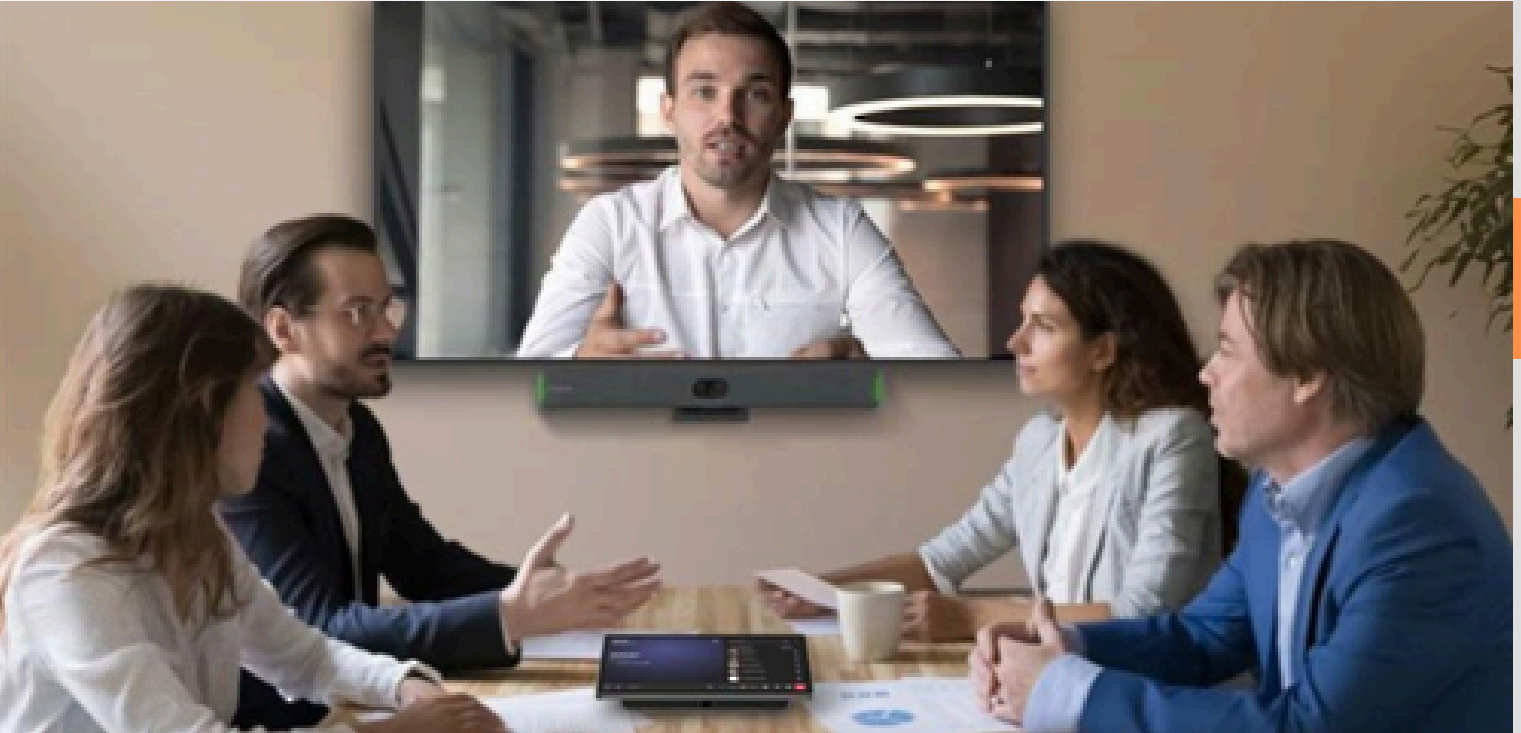

The MAXHUB XBar V50 Kit is a **Teams-certified** videobar built on MDEP Android, designed for small to medium rooms.

### Features:

- Plug 'n' Play functionality
- 100MP dual-lens camera system
- 12 beamforming microphones with 8m pickup range
- AI-enhanced audio
- Content share 4K local via HDMI or USB-C
- CEC display control
- Dual Screen Capability
- FlexMount included for easy installation

Datasheet



Mechanical Drawing



\* Optional Wireless Dongle WT13M

# V70

## All-in-one Android-based Videobar

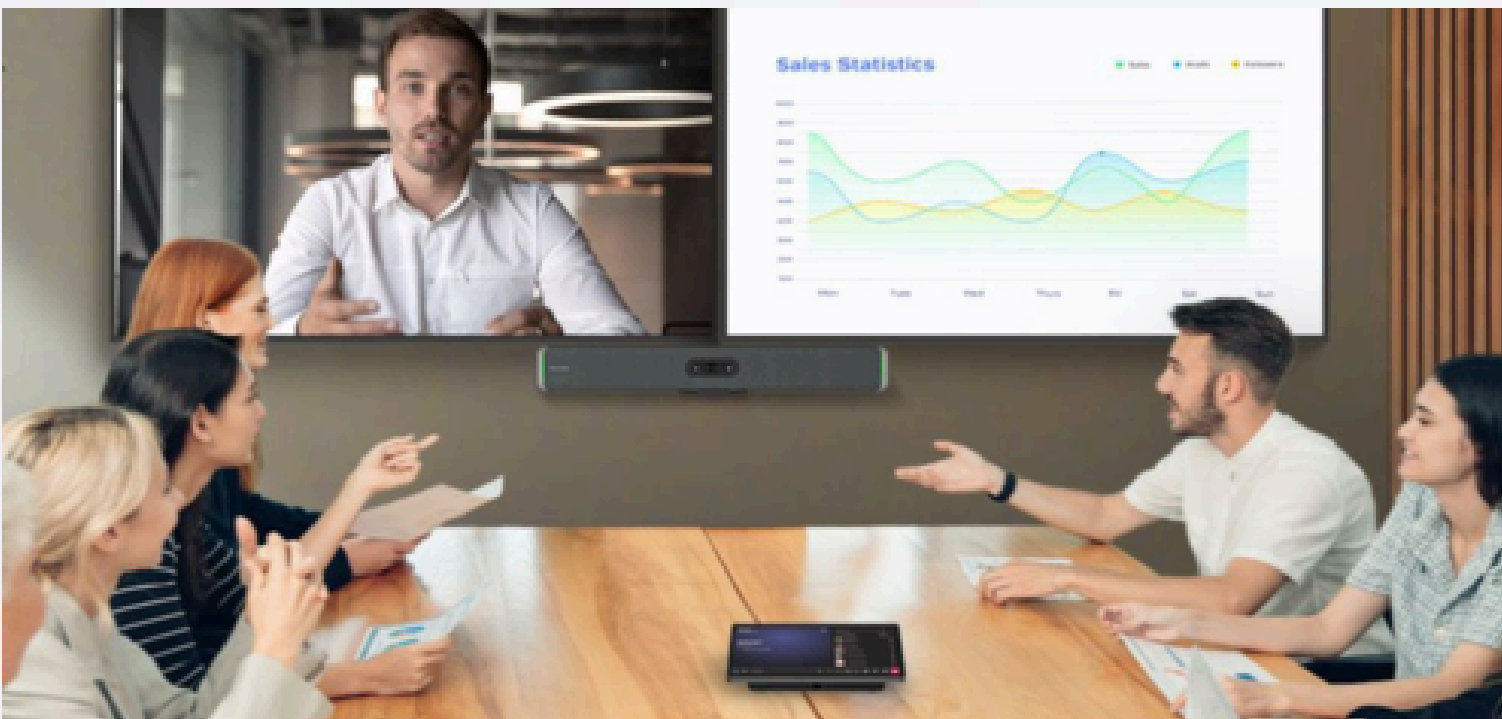

The MAXHUB XBar V70 Kit is a **Teams-certified** videobar built on MDEP Android, designed for small to medium rooms.

### Features:

- Plug 'n' Play functionality
- 100MP dual-lens camera system
- 12 beamforming microphones with 8m pickup range
- AI-enhanced audio
- Content share 4K local via HDMI or USB-C
- CEC display control
- Dual Screen Capability
- FlexMount included for easy installation

Datasheet



Mechanical Drawing



\* Optional Wireless Dongle WT13M

# W70

## A Windows-based Microsoft Teams Videobar

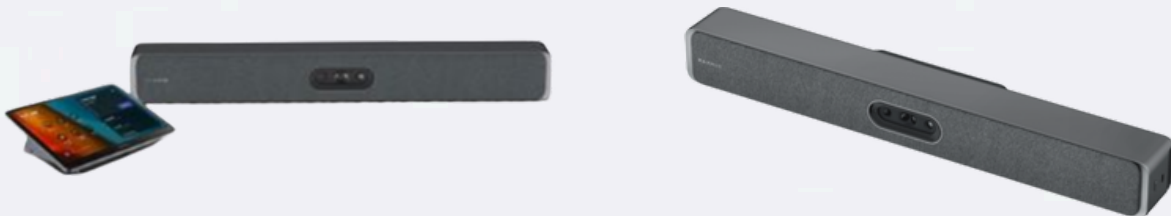
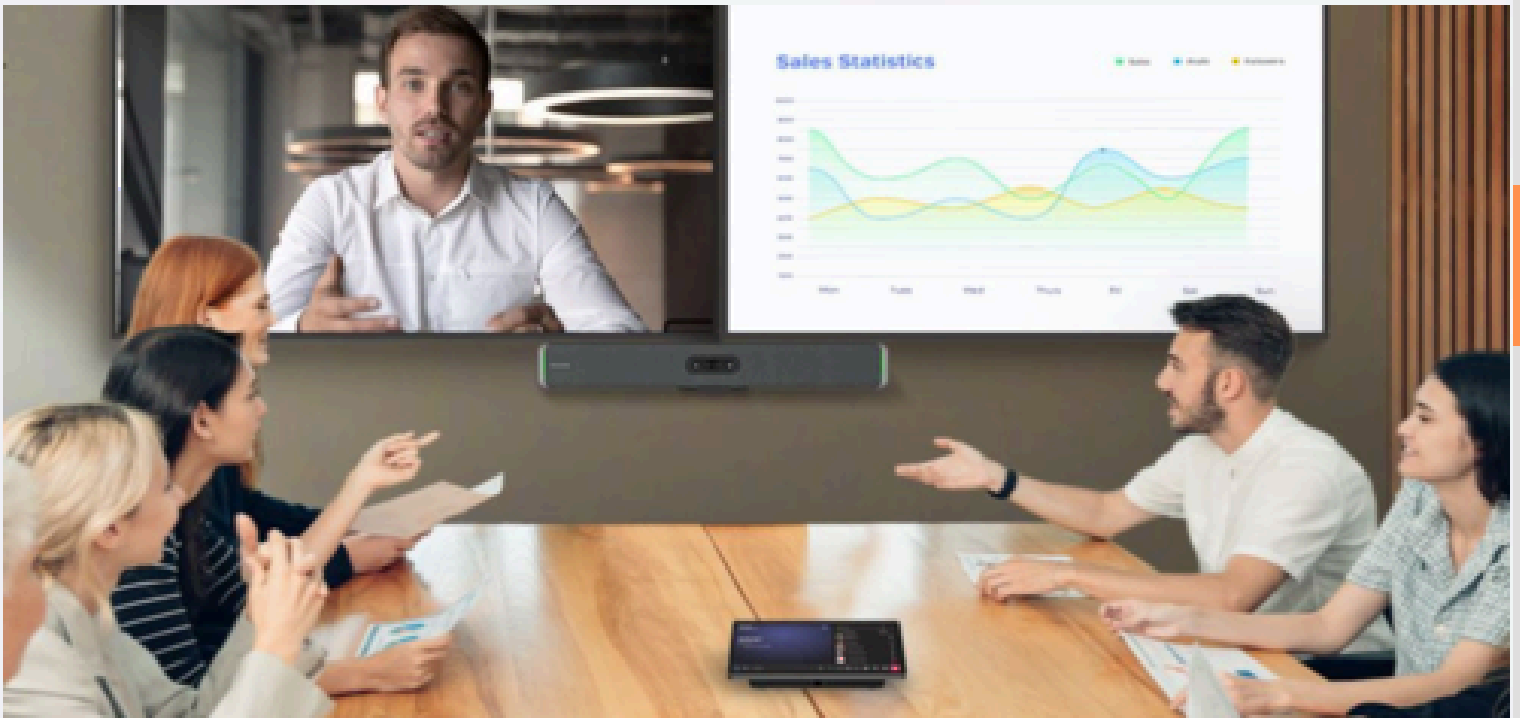

The MAXHUB XBar W70 is a flagship Windows-based Teams videobar engineered for medium to large rooms.

### Features:

- Plug 'n' Play functionality
- 200MP Quad sight lens camera with auto framing, speaker tracking, Intelligent focus smart gathering and video fence
- 125deg FOV and dual telephoto camera
- Automatic privacy shutter
- Dual 20w speakers
- 16 microphone array for 10m pick up range
- Content share 1080p local via HDMI or USB-C
- CEC display control
- FlexMount included
- Remote Management
- 3 year warranty

\* Optional Wireless Dongle WT13M

Datasheet



Mechanical Drawing



# XCORE KIT

## Microsoft Teams Room



Elevate your focus and BYOD meeting spaces with the MAXHUB XCore Kit, a certified entry-level Microsoft Teams Room solution that includes a console and a Windows-based computer.

### Features:

- Windows 11 IoT
- Intel 12th Gen 10-Core i3 processor
- High-resolution 10.1-inch Teams Rooms console
- Content share local via HDMI
- CEC display control
- 3-year advanced replacement warranty

Brochure



Datasheet



\* Please add usb camera and microphone options

# XCORE KIT PRO

## Pro Microsoft Teams Room



Maxhub Xcore Kit Pro is a certified Microsoft Teams Room conferencing solution designed for medium to extra large meeting rooms.

### Features:

- Windows 11 IoT Enterprise SAC
- 12th Gen Intel® i5 Processor
- High-resolution 10.1-inch Teams Rooms console
- Content share 4K local via HDMI or USB-C
- CEC display control
- 3-year advanced replacement warranty

Brochure



Datasheet



\* Please add usb camera and microphone options

# P30

## MAXHUB UC Camera 4K PTZ P30



Experience superior visual quality and expanded coverage with a USB 3.0 dual-camera system. Sony 1.8-inch, 8MP image sensors capture detailed 4K video from multiple viewpoints.

### Features:

- Dual-camera system
- USB 3.0 Connectivity
- Sony 1.8-inch, 8MP image sensors capture detailed 4K video
- F1.8 aperture lens
- 12x optical and 16x digital zoom
- 90° DFOV provides comprehensive coverage
- Seamless AI integration
- 360° gimbals rotation and expanded preset positions
- Microsoft Certified

Datasheet













Brochure



# XBOARD V7 MTR

All-in-One Microsoft Teams Rooms Interactive Touch Display









Image	SKU	Size	Datasheet
	V555T	55"	
	V655T	65"	
	V755T	75"	
	V865T	86"	
	V925T	92"	

**Features:**

- AI Powered Trident Lens Camera System
- Built-in 16 Microphone Array with 8m Pickup
- 4K Display 50 Point Intelligent Touchscreen Technology
- Native Microsoft Teams Room Whiteboarding & Touch Sensing
- Automatic Sleep and Wake-Up with Motion Sensor Detection
- Plug n Play USB-C, HDMI and Wireless Connectivity
- Windows 11 IoT

# XBOARD V7

## All-in-One Conferencing Interactive Touch Display

Image	SKU	Size	Datasheet
	V5550	55"	
	V6550	65"	
	V7550	75"	
	V8650	86"	

### Features:

- AI Powered Trident Lens Camera System
- Built-in 16 Microphone Array with 8m Pickup
- 4K Display 50 Point Intelligent Touchscreen Technology
- Whiteboarding & Touch Sensing
- Automatic Sleep and Wake-Up with Motion Sensor Detection
- Plug n Play USB-C, HDMI and Wireless Connectivity
- Teams, Zoom, Google and Webex Capabilities

# WT13M

## Wireless Screen Sharing Dongle



### Features:

- 5s Rapid pairing
- No Installation or Driver Required
- Ultra HD 4K Support
- Wifi 6 connectivity with spatial multiplexing
- Touchback control and pen annotation
- BYOM (Bring your own meeting) support
- USB Type-C Interface and Type-A Adapter
- NFC one touch sharing



Datasheet



# Nureva HDL Series

## Audio Conferencing System

The HDL series are whole room audio conferencing systems designed to deliver clear, full-room pickup for meeting spaces and classrooms. They use patented Microphone Mist™ technology, which fills a room with thousands of virtual microphones to capture voices from anywhere. This ensures natural conversations, seamless collaboration, and simplified installation compared to traditional systems.

Image	SKU	Features	Datasheet
	HDL200	<ul style="list-style-type: none"> <li>Up to 6m x 6m full room mic pick up</li> <li>Continuous autocalibration</li> <li>Intelligent Sound Tracking</li> <li>Position based gain control</li> <li>Flexible installation</li> <li>Plug n Play with USB</li> </ul>	
	HDL310	<ul style="list-style-type: none"> <li>Up to 10m x 10m full room mic pick up</li> <li>Continuous autocalibration</li> <li>Divisible rooms</li> <li>Camera Integrations</li> <li>Easy Installation</li> <li>Plug n Play with USB</li> </ul>	
	HDL410	<ul style="list-style-type: none"> <li>Up to 11m x 17m full room mic pick up</li> <li>Continuous autocalibration</li> <li>Divisible rooms</li> <li>Camera Integrations</li> <li>Adaptive voice amplification</li> <li>Easy Installation</li> <li>Plug n Play with USB</li> </ul>	

# HDX SERIES

## Full-Room Pro Audio Series



### Features:

- Up to 12m x 18m full room microphone coverage
- Full range distributed audio
- Adaptive voice lift
- Adaptive voice amplification
- Assistive listening with Auracast broadcast audio
- Divisible room automation
- 3D sound location data
- Fast Track Setup and Configuration
- Modular to accomodate various room applications

# BYOM

## Bring Your Own Meeting Room Solution

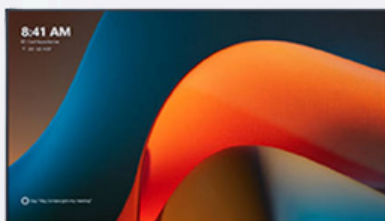

This all-in-one Maxhub BYOM Conferencing Bundle offers a complete, seamless solution for high-quality virtual meetings, designed to be plug-and-play for ease of use.

### Features:

- Plug n Play Functionality
- 65" 4K commercial display
- 4K All-in-One Videobar with 8m pick up
- USB wireless dongle (USB-C/A)
- Content share 4K local via USB-C or USB wireless dongle
- Wall mounts included

# SMMTR

## Small to Medium Microsoft Teams Room Solution



### Features:

- Plug n Play Functionality
- 65" 4K commercial display
- 4K All-in-One Videobar with 8m pick up and Touch Console
- USB wireless dongle (USB-C/A)
- Content share 4K local via USB-C or HDMI & USB wireless dongle
- Wall mounts included



**AV** Supply Group Ltd

# Display Solutions

## **VESTEL** **MAXHUB**

Discover a wide range of professional display solutions designed to deliver clear visuals and lasting performance across commercial, educational, and corporate environments.













From interactive flat panels and digital signage to commercial-grade monitors and video walls, these displays are built for reliability, flexibility, and high-impact viewing.

Ideal for boardrooms, classrooms, retail, and control rooms—experience seamless integration and vibrant visuals that command attention.

# CMB SERIES

## Professional Commercial Displays

The MAXHUB CMB Series comprises 4K commercial-grade displays tailored for meeting rooms, digital signage, and collaborative environments. These panels feature non-glare and conformal coatings, robust build quality, and smart features for seamless connectivity and management.

Image	SKU	Size	Datasheet
	ND43CMB	43"	
	ND55CMB	55"	
	ND65CMB	65"	
	ND75CMB	75"	
	ND86CMB	86"	
	ND98CMB	98"	





### Features:

- 4K UHD Resolution
- Commercial Grade 24/7 Operation
- 500nit Brightness with anti-glare
- Built-in Maxhub Share & Dual WiFi
- BYOD Technology with USB-C, Maxhub Share or USB Wireless Dongle
- Landscape & Portrait Orientation
- 3 Year Warranty

# UW SERIES

## UltraWide Commercial Display

The MAXHUB UW Series brings immersive ultra-wide 21:9 displays to modern workplaces, designed to enhance hybrid collaboration and content sharing. Available in 92" and 105" sizes, these 5K resolution displays deliver a premium front-row meeting experience with powerful connectivity and seamless integration.

Image	SKU	Size	Datasheet
	UW92NA	92"	
	UW105	105"	





### Features:

- 21:9 Ultra-Wide 5K Display
- Optimized for Microsoft Teams Rooms
- Flexible OS Options
- Comprehensive Connectivity
- Enterprise Integration
- Landscape & Portrait Orientation

# PRIME SERIES

## Professional UHD Signage Displays 24/7

The Vestel Prime Series digital signage displays combine 4K UHD visuals, embedded Android performance, and robust commercial features, making them ideal for retail, corporate, and public environments.

Image	SKU	Size	Datasheet
	PN55	55"	
	PN65	65"	







### Features:

- 4K UHD Resolution with High Brightness
- Embedded Android SoC (VAP400 Platform)
- USB Auto-Play with Secured USB Port
- Built-in Scheduler for Automated Content & Power Control
- Open API & CMS Integration Support
- Landscape & Portrait Orientation

# EXTREME SERIES

## Professional UHD Signage Displays 24/7

The Vestel Extreme Series delivers robust 4K UHD digital signage designed for demanding environments. Available in 75", 86", and 98" models, these displays run 24/7 and feature a polished design with powerful SoC control for seamless content management and reliable performance.

Image	SKU	Size	Datasheet
	XN75	75"	
	XN86	86"	
	XN98	98"	

### Features:

- 4K UHD Resolution with 500 cd/m<sup>2</sup> Brightness
- Embedded Android SoC (VAP400) with 2 GB RAM & 16 GB Storage
- USB Auto-Play with Secure, Screw-Protected USB Cover
- Signal Failover & Pixel-Shifting to Ensure Always-On Performance
- Daisy-Chain Support
- Landscape & Portrait Orientation

**AV** Supply Group Ltd

# Display Mount Solutions

## Residential

**SANUS**<sup>®</sup>

A brand of **legrand**

**SECURA**



Enhance your home entertainment setup with a range of reliable and stylish mounting solutions for TVs and displays.

From fixed and tilting wall mounts to full-motion, each option is designed for easy installation, space-saving convenience, and secure support.

Perfect for living rooms, bedrooms, or media rooms—achieve the perfect viewing angle with mounts built for both function and form.

# VLL5-B2

## Sanus Premium Large Fixed Wall Mount for TVs 42" - 90"

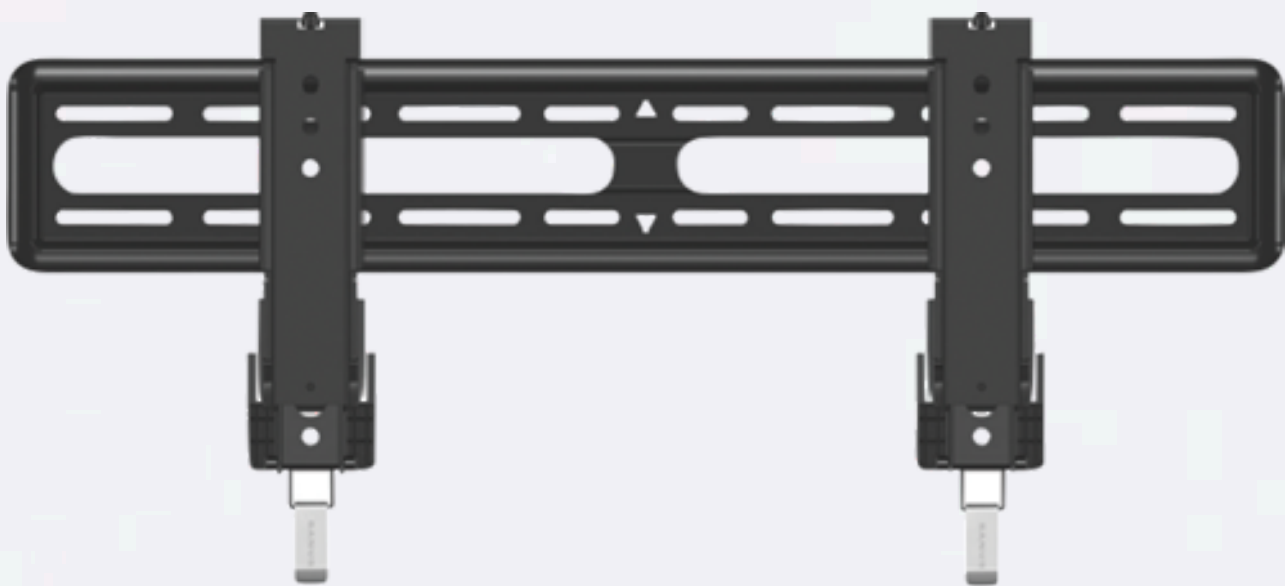

### Features:

- Fits TVs from 42" to 90"
- Vesa support upto 675 x 410mm
- 79kg weight rating
- Leveling adjustments post hanging
- Safety Tested and UL Certified
- Thin Install
- Pull down on hidden straps to access cables behind your TV
- 10 year warranty

Installation Manual



Technical Drawing



# VMPL50A

Sanus Premium Large Tilting wall mount for  
TVs 32" - 85"



## Features:

- Fits TVs from 32" to 85"
- Vesa support upto 670 x 435mm
- 68kg weight rating
- Virtual Axis™ tilting system for easy adjustment
- Post-installation height and leveling adjustment
- Safety Tested and UL Certified
- 10 year warranty

Installation Manual



Technical Drawing



# VLT6-B2

Sanus Premium Large Tilting wall mount for  
TVs 46" - 90"



## Features:

- Supports TVs from 46" to 90"
- Vesa support upto 690 x 415mm
- 68kg weight rating
- 145mm extension from wall
- Safety Tested and UL Certified
- 10 year warranty

Installation Manual



Technical Drawing



# VLT7

## Advanced Tilt 4D Premium TV Wall Mount For 42" - 90" TVs



### Features:

- Supports TVs from 42" to 90"
- Vesa support upto 600 x 400mm
- 68kg weight rating
- 172mm extension from wall
- Safety Tested and UL Certified
- 10 year warranty

Installation Manual



Product Sell Sheet



# VXT7

## Tilting TV Wall Mount for 65" - 110" TVs

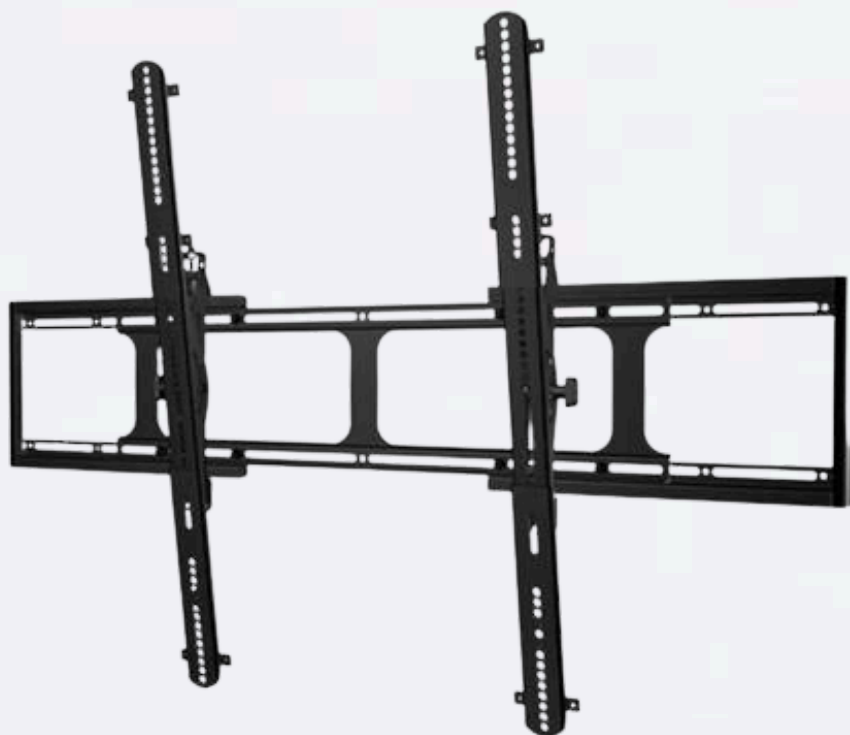

### Features:

- Supports TVs from 65" to 110"
- Vesa support upto 1100 x 800mm
- Virtual Axis™ tilting system for easy adjustment
- 136kg weight rating
- Safety Tested and UL Certified
- 10 year warranty

Installation Manual



Product Sell Sheet



# VLF728-B2

Sanus Premium Large Full motion mount for  
TVs 42" - 90"

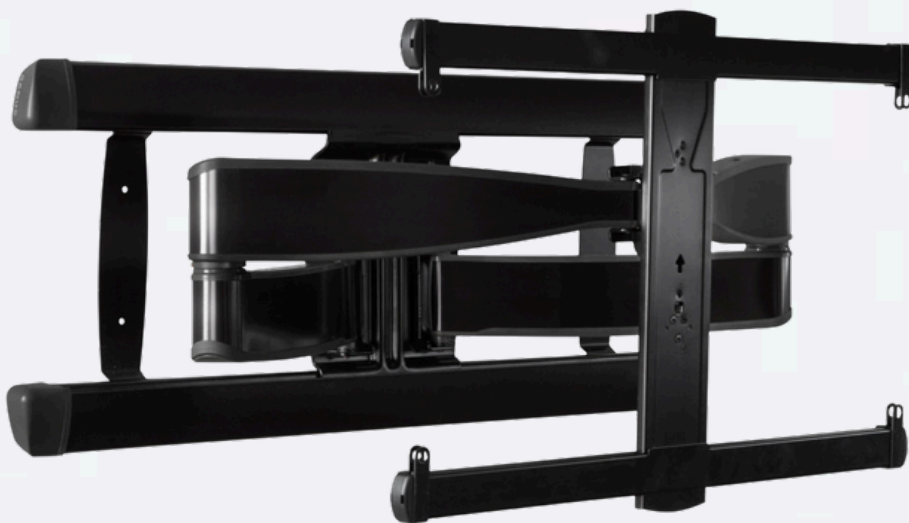

## Features:

- Supports TVs up to 90"
- 56kg weight rating
- Vesa support upto 600 x 400mm
- FluidMotion™ design for effortless movement
- Tilt and swivel motion
- 711mm extension from wall
- Dual stud mounting
- Safety Tested and UL Certified
- 10 year warranty

Installation Manual



Product Sell Sheet



# VMF720-B2

Sanus Premium Medium Full motion mount for  
TVs 32" - 65"



## Features:

- Fits TVs from 32" to 65"
- 25kg weight rating
- Vesa support upto 400 x 400mm
- FluidMotion™ design for smooth movement
- Tilt and swivel motion
- 500mm extension from wall
- Single stud mounting
- Safety Tested and UL Certified
- 10 year warranty

Installation Manual



Technical Drawing



# VSF716-B2

Sanus Premium Small Full motion mount for  
TVs 19" - 43"



## Features:

- Fits TVs from 19" to 43"
- 15kg weight rating
- Vesa support upto 200 x 200mm
- FluidMotion™ technology for smooth movement
- Tilt and swivel motion
- 400mm extension from wall
- Single stud mounting
- Safety Tested and UL Certified
- 10 year warranty

Installation Manual



Technical Drawing



# QLF314-B2

## Secura Large Full Motion Wall Mount for TVs 40" - 70"



### Features:

- Supports TVs 40"–70"
- 36kg weight rating
- Vesa support upto 620 x 410mm
- 355mm extension and 45° swivel left and right
- Tilt range: +5° to -15°
- Single stud mounting
- 5 year warranty

Installation Manual



Technical Drawing



# QLT35-B2

Secura Large Tilting Wall Mount for  
TVs 40" - 90"

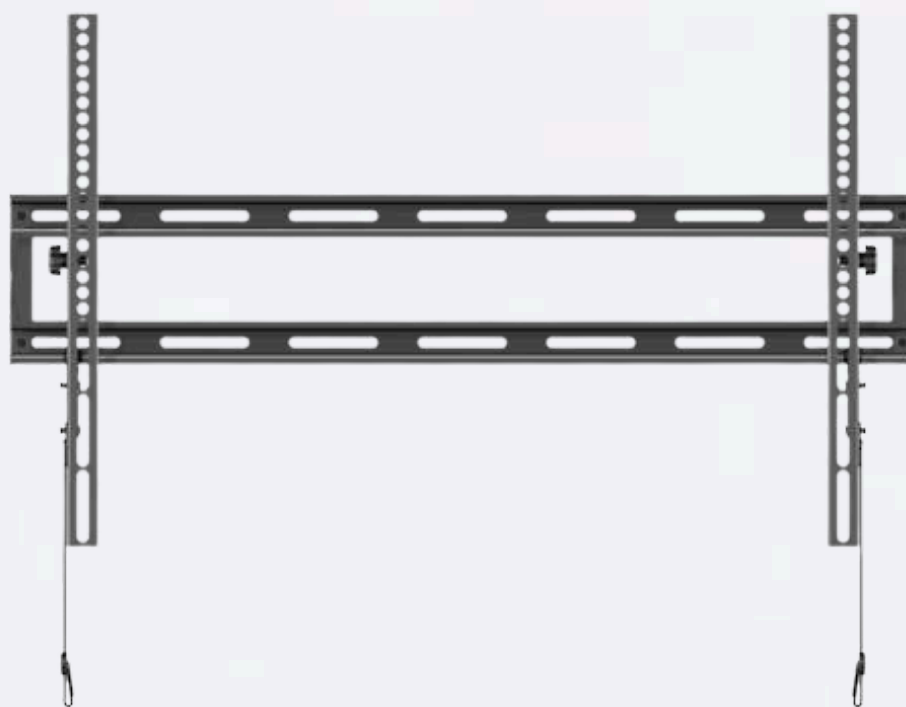

## Features:

- Fits TVs 40"–90"
- 49kg weight rating
- Vesa support upto 600 x 400mm
- Tilt range: +5° to -15°
- Low profile design
- 5 year warranty

Installation Manual



Technical Drawing



# QLL23-B2

Secura Large Fixed Wall Mount for  
TVs 40" - 90"



## Features:

- Supports TVs 40"– 90"
- 54kg weight rating
- Vesa support upto 700 x 400mm
- Low profile design
- 5 year warranty

Installation Manual



# PSTVS02

## Perlesmith Swivel TV Stand



### Features:

- Supports TVs from 32" to 75"
- VESA patterns up to 600x400mm
- -35° to +35° rotation for optimal viewing angles
- Adjustable Height Settings:
- Integrated Cable Management

Installation Manual



Product Sellsheet



# PSTVS01-2

## Perlesmith Support Legs



The Perlesmith PSTVS01-2 is a minimalist tabletop TV stand designed for 37" to 70" flat-screen TVs weighing up to 50 kg (110 lbs). It features a solid steel construction for enhanced durability and stability.

### Features:

- Heavy-Duty Steel Construction: Supports TVs up to 50 kg
- Easy Installation: Quick assembly with all hardware included
- Supports TVs 40"–70" up to 100 lbs
- Universal VESA compatibility

Installation Manual



**AV** Supply Group Ltd

# Display Mount Solutions Commercial

## CHIEF®

A brand of  **legrand®**

Support your professional AV setup with a robust range of mounting solutions built for commercial environments.

From wall mounts and ceiling mounts to mobile trolleys and video wall systems, these solutions offer stability, flexibility, and clean installation across boardrooms, retail spaces, control centres, and conference rooms.







Designed for durability and ease of use—achieve the perfect display position for any space.

**CHIEF** offers best in class commercial mounting solutions - inspired by installers whilst **AVS** offers exceptional value for your professional mounting solutions

# FUSION SERIES - FIXED

## Fixed Micro-Adjustable Wall Mount

The Chief Fusion fixed wall mounts feature micro-adjustable durable construction, and integrated cable management for clean, professional installations in corporate, retail, or residential settings.

Image	SKU	Specs	Datasheet
	MSM1U	<ul style="list-style-type: none"> <li>• 32"–75" display sizes</li> <li>• 56.7kg weight capacity</li> <li>• Up to 650 x 400mm vesa</li> <li>• Seismic rated</li> <li>• UL Listed</li> </ul>	
	LSM1U	<ul style="list-style-type: none"> <li>• 42"–86" display sizes</li> <li>• 90.7kg weight capacity</li> <li>• Up to 800 x 500mm vesa</li> <li>• Seismic rated</li> <li>• UL Listed</li> </ul>	
	XSM1U	<ul style="list-style-type: none"> <li>• 55"–100" display sizes</li> <li>• 113.4kg weight capacity</li> <li>• Up to 1070 x 600mm vesa</li> <li>• Seismic rated</li> <li>• UL Listed</li> </ul>	









### Features:

- Micro-Adjustable - Fine-tune the vertical angle of the display after installation
- Integrated Cable Management – Keeps wires organized and hidden
- Durable Construction – Supports heavy displays securely
- Quick-Connect System – Tool-free installation for faster setup

# FUSION SERIES - TILT

## Tilting Micro-Adjustable Wall Mount

The Chief Fusion tilting wall mounts feature micro-adjustable tilt, durable construction, and integrated cable management for clean, professional installations in corporate, retail, or residential settings.

Image	SKU	Specs	Datasheet
	MTM1U	<ul style="list-style-type: none"> <li>• 32"–75" display sizes</li> <li>• 56.7kg weight capacity</li> <li>• Up to 650 x 400mm vesa</li> <li>• Seismic rated</li> <li>• UL Listed</li> </ul>	
	LTM1U	<ul style="list-style-type: none"> <li>• 42"–86" display sizes</li> <li>• 90.7kg weight capacity</li> <li>• Up to 800 x 500mm vesa</li> <li>• Seismic rated</li> <li>• UL Listed</li> </ul>	
	XTM1U	<ul style="list-style-type: none"> <li>• 55"–100" display sizes</li> <li>• 113.4kg weight capacity</li> <li>• Up to 1070 x 600mm vesa</li> <li>• Seismic rated</li> <li>• UL Listed</li> </ul>	
	MTMP1U	<ul style="list-style-type: none"> <li>• 42"–86" display sizes</li> <li>• 90.7 kg weight capacity</li> <li>• Up to 570 x 600mm vesa</li> <li>• Seismic rated</li> <li>• UL Listed</li> </ul> <p style="text-align: center;">*Portrait model</p>	









### Features:

- Micro-Adjustable - Fine-tune the vertical angle of the display after installation
- Integrated Cable Management – Keeps wires organized and hidden
- Durable Construction – Supports heavy displays securely
- Quick-Connect System – Tool-free installation for faster setup

# FUSION SERIES - CEILING

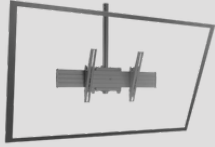
## Flat Panel Ceiling Mount

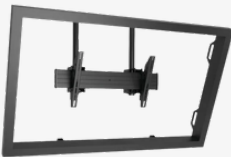
The Chief Fusion ceiling mounts provide secure, low-profile support for flat-panel displays from above. They feature adjustable height, micro-positioning, and integrated cable management, making them ideal for classrooms, offices, retail, or commercial spaces.

Image	SKU	Specs	Datasheet
	MCM1U	<ul style="list-style-type: none"> <li>• 32"-65" display sizes</li> <li>• 56.7 kg weight capacity</li> <li>• Up to 460 x 400mm vesa</li> <li>• Seismic rated</li> <li>• UL Listed</li> </ul>	
	LCM1U	<ul style="list-style-type: none"> <li>• 42"-75" display sizes</li> <li>• 56.7kg weight capacity</li> <li>• Up to 600 x 400mm vesa</li> <li>• Seismic rated</li> <li>• UL Listed</li> </ul>	
	XCM1U	<ul style="list-style-type: none"> <li>• 55"-100" display sizes</li> <li>• 113.4kg weight capacity</li> <li>• Up to 800 x 400mm vesa</li> <li>• Seismic rated</li> <li>• UL Listed</li> </ul>	
	XCM7000	<ul style="list-style-type: none"> <li>• 55"-100" display sizes</li> <li>• 1136kg weight capacity</li> <li>• Up to 800 x 400mm vesa</li> <li>• Seismic rated</li> <li>• UL Listed</li> </ul>	

### Features:

- Adjustable Height – Customize the distance from ceiling to display
- Micro-Adjustable Positioning – Fine-tune horizontal and vertical alignment after installation
- Integrated Cable Management – Keeps wires organized and concealed
- Durable Construction – Supports heavy displays safely and reliably

# FIT3 SERIES DISPLAY MOUNTS

**Meet the next generation of high value display mounts**

**Features:**

- Low-profile depth facilitates ADA compliance for typical AV design requirements
- Easy to reach leveling screw for post-installation adjustments 0.75" (19 mm)
- Open wall plate for flexible positioning around power and data wall boxes
- Enhanced rigid wall plate and additional mounting slots for improved installation experience
- Tool-free GlideLock secures display to wall plate, allows perfect positioning of screen
- Magnetic quick-store release pull cords allow easy access to cable connections
- Theft deterrent security options (not included)
- UL and TUV safety standards compliant

**Fit™ Fixed Wall Mount**

Part #	Description	Max. Mounting Pattern	Typical Screen Sizes	Weight Capacity	Certifications
<b>RMF3</b>	Medium Fit™ Fixed Display Wall Mount	550 x 450mm	32 - 65"	125 lbs (56.7 kg)	UL and TUV
<b>RLF3</b>	Large Fit™ Fixed Display Wall Mount	960 x 450mm	43 - 86"	200 lbs (90.7 kg)	UL and TUV
<b>RXF3</b>	Extra-Large Fit™ Fixed Display Wall Mount	960 x 650mm	49 - 98"	250 lbs (113 kg)	UL and TUV

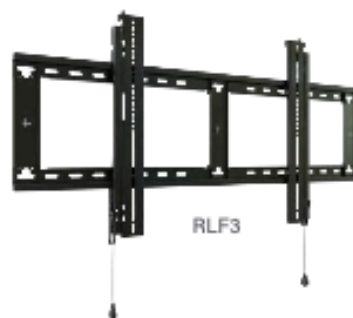

**Fit™ Tilt Wall Mount**

- Display can be tilted up to 12° to set the optimal viewing angle

Part #	Description	Max. Mounting Pattern	Typical Screen Sizes	Weight Capacity	Certifications
<b>RMT3</b>	Medium Fit™ Tilt Display Wall Mount	508 x 450mm	32 - 65"	125 lbs (56.7 kg)	UL and TUV
<b>RLT3</b>	Large Fit™ Tilt Display Wall Mount	915 x 450mm	43 - 86"	200 lbs (90.7 kg)	UL and TUV
<b>RXT3</b>	Extra-Large Fit™ Tilt Display Wall Mount	915 x 650mm	49 - 98"	250 lbs (113 kg)	UL and TUV

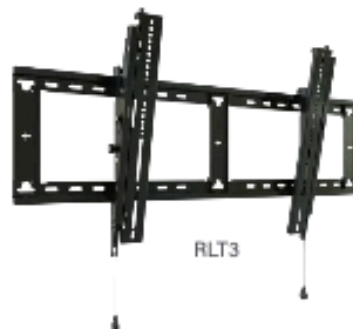

**Fit™ Extending Tilt Wall Mount**

- Minimum 2.67" (68 mm) depth up to 6" (152 mm) when fully extended away from the wall
- 10° forward and back tilt

Part #	Description	Max. Mounting Pattern	Tilt	Maximum Extension	Typical Screen Sizes	Weight Capacity	Certifications
<b>RLXT3</b>	Large Fit™ Extending Tilt Display Wall Mount	100 x 100 - 863 x 450mm	+10°/-10°	6" (152 mm) from wall	43 - 85"	150 lbs (68 kg)	UL and TUV



# CHIEF FULL MOTION

The Chief wall mounts provide secure, low-profile support for flat-panel displays. Ideal for classrooms, offices, retail, or commercial spaces.

Image	SKU	Specs	Datasheet
	PDRUB	<ul style="list-style-type: none"> <li>• 42 - 98" display sizes</li> <li>• 90.7kg weight capacity</li> <li>• Up to 860 x 517mm vesa</li> <li>• UL Listed</li> </ul>	
	TS525TU	<ul style="list-style-type: none"> <li>• 37-75" display sizes</li> <li>• 56.7kg weight capacity</li> <li>• Up to 800 x 400mm vesa</li> <li>• Seismic rated</li> <li>• UL Listed</li> </ul>	
	TS318TU	<ul style="list-style-type: none"> <li>• 32-65" display sizes</li> <li>• 34kg weight capacity</li> <li>• Up to 600 x 400mm vesa</li> <li>• Seismic rated</li> <li>• UL Listed</li> </ul>	

## Features:

- Dual swing arms for maximum extension
- height adjustment
- Lateral shift
- Micro adjustment
- Swivel and Tilt
- Low Profile design
- Integrated cable management
- 10 year warranty

# LVS1U

## ConnexSys Video Wall Mount

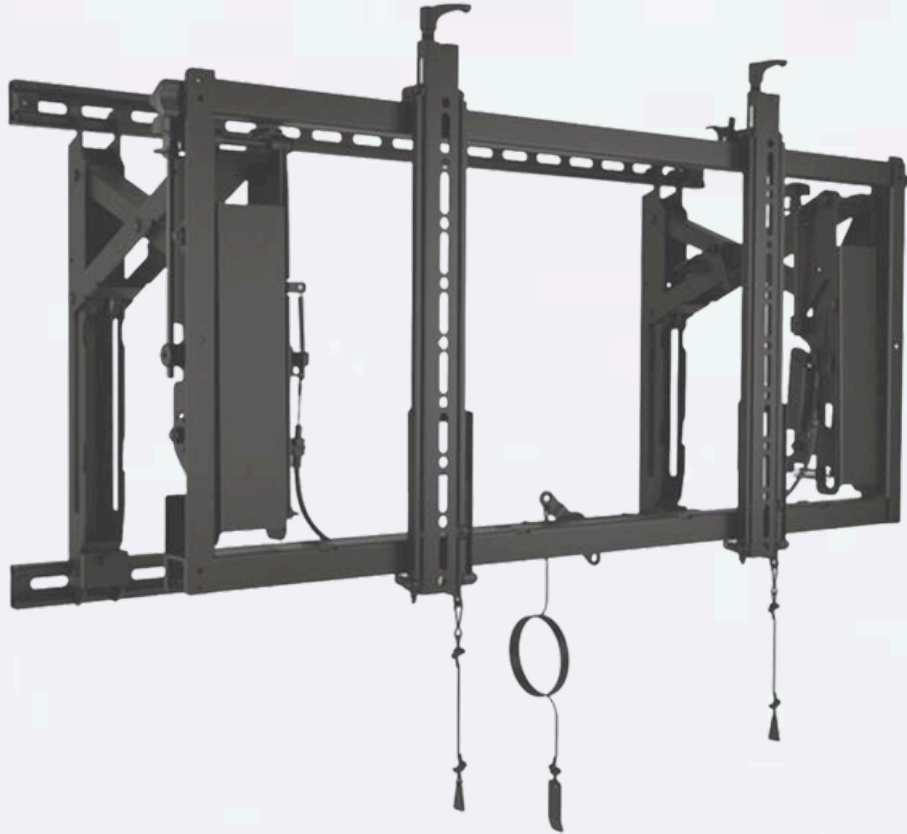

The Chief LVS1U is a sleek, low-profile video wall mount designed for seamless large-format display installations in professional environments.

### Features:

- Supports ultra-thin displays for a clean, modern look.
- Tool-less 6 point micro-adjustments simplify display alignment.
- Robust steel construction ensures long-lasting durability.
- Compatible with VESA mounting patterns up to 700×400.
- Quick-release design allows fast installation and service access.
- 340mm maximum extension
- 68kg weight rating
- Seismic rated
- UL Listed

Installation Manual



Technical Drawing



# AS3LD

## Tempo Flat Panel Wall Mount System



### Feature Flexibility

- Wall plate and extending interface design facilitates centering display in the right position.
- 10° of adjustable display tilt in 2.5° increments.

### Integrated Storage

- Ships with two 15" x 10" Lever Lock™ plates with space to add more.
- Storage plates can be moved along the mounting rail for best placement of components.

### Simplify Service

- 320 mm of service access with extendable arm
- Open wall plate for easy positioning of power and data sources and in-wall storage.

Installation Manual









Technical Drawing

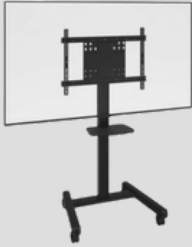

# PREMIUM MOBILE SOLUTIONS







## Premium Mobile Carts for Displays

Image	SKU	TV Size	Specs	Datasheet
	RFCUB	55" - 86"	<ul style="list-style-type: none"> <li>• Supports VESA mounting patterns from 200x200 to 800x600.</li> <li>• 76kg weight capacity</li> <li>• Three selectable height locations at 112cm, 132cm and 153cm accommodate accessibility for a wide range of users.</li> <li>• Height-adjustable shelf is included to store up to 10lbs of accessories like keyboards, laptops, and styluses.</li> </ul>	
	LPAUB	42" - 86"	<ul style="list-style-type: none"> <li>• Micro-Adjustable, and Height Adjustable</li> <li>• Supports VESA mounting patterns from 200 x 200 - 800 x 400 mm</li> <li>• 90.7kg weight capacity</li> <li>• Post-Installation Leveling</li> <li>• UL Listed</li> </ul>	
	XPA1UB	55" - 100"	<ul style="list-style-type: none"> <li>• Micro-Adjustable, Height Adjustable</li> <li>• Supports VESA mounting patterns from 200 x 200mm - 800 x 400mm</li> <li>• 136kg weight capacity</li> <li>• Post-Installation Leveling</li> <li>• TAA compliant</li> <li>• UL Listed</li> </ul>	

- About
- Content
- AV Accessories
- Cables & Connectivity
- Conferencing Solutions
- Display Solutions
- Display Mount Residential
- Display Mount Commercial**
- Furniture Solutions
- Motorised Mount Solutions
- Projection Solutions
- Racking Solutions
- Networking Solutions
- Contact Details

# ENTRY MOBILE SOLUTIONS

## High Value Mobile Carts for Displays

Image	SKU	TV Size	Product Specifications	Datasheet
	SAVC3780	37" - 86"	<ul style="list-style-type: none"> <li>• Large, lockable wheels</li> <li>• Adjustable component and camera shelves</li> <li>• Supports VESA mounting patterns from 200 x 200 - 700 x 600mm</li> <li>• Title Range: -15° to 15°</li> <li>• 125kg Weight capacity</li> <li>• 10 Year warranty</li> </ul>	
	SAVC5590	55" - 90"	<ul style="list-style-type: none"> <li>• Large, lockable wheels</li> <li>• Adjustable component and camera shelves</li> <li>• Supports VESA mounting patterns from 200 x 200 - 860 x 600mm</li> <li>• Title Range: -15° to 15°</li> <li>• 125kg Weight capacity</li> <li>• 10 Year warranty</li> </ul>	
	ST33M	55" - 86"	<ul style="list-style-type: none"> <li>• Upto 800 x 600mm Vesa</li> <li>• 100kg Weight capacity</li> <li>• 5 Year warranty</li> </ul>	

**AV** Supply Group Ltd

# Motorised Mount Solutions







## NEXUS<sub>21</sub> MAXHUB

### TOUCHBOARD

Our motorised display mount solutions offer smooth, effortless screen adjustment at the touch of a button, providing flexibility and comfort in any space. Available in floor, wall, ceiling, and mobile cart options, these mounts allow easy height or tilt control for perfect viewing angles in homes, offices, classrooms, meeting rooms, and public areas. Designed for stability and style, they deliver quiet, reliable performance and a clean, professional appearance in every setting.







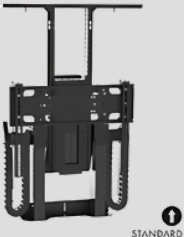

# UP TO 65" TV LIFTER

## Pop-up TV lift

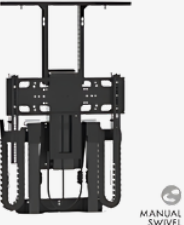
Image	SKU	TV Size	Description	Datasheet
	L65	42" - 65"	<ul style="list-style-type: none"> <li>• 978 mm extension</li> <li>• Fully extends in 25 seconds</li> <li>• Quiet operation at 45dB</li> <li>• No exposed gears, tracks or scissors</li> <li>• Easy installation</li> <li>• Remote control and integration hub included</li> <li>• Easy installation</li> <li>• 45kg weight capacity</li> <li>• 10 Year warranty</li> </ul>	
	L65s	42" - 65"	<ul style="list-style-type: none"> <li>• 978 mm extension</li> <li>• 360° degree manual swivel</li> <li>• Fully extends in 25 seconds</li> <li>• Quiet operation at 45dB</li> <li>• Easy installation</li> <li>• Remote control and integration hub included</li> <li>• Easy installation</li> <li>• 45kg weight capacity</li> <li>• 10 Year warranty</li> </ul>	
	L65x	42" - 65"	<ul style="list-style-type: none"> <li>• 978 mm extension</li> <li>• Motorised swivel</li> <li>• Two programmable preset positions</li> <li>• Fully extends in 25 seconds</li> <li>• Quiet operation at 45dB</li> <li>• Remote control and integration hub included</li> <li>• Easy installation</li> <li>• 45kg weight capacity</li> <li>• 10 Year warranty</li> </ul>	

# UP TO 86" TV LIFTER

## Floor Pop Up TV Lift

Image	SKU	TV Size	Description	Datasheet
 <p>STANDARD</p>	L85	65-86"	<ul style="list-style-type: none"> <li>• 1320 mm extension</li> <li>• Fully extends in 18 – 30 seconds depending on weight load</li> <li>• Quiet operation at just 50 dB</li> <li>• Remote control and integration hub included</li> <li>• Easy installation</li> <li>• 79kg weight capacity</li> <li>• 10 Year warranty</li> </ul>	
 <p>MANUAL SWIVEL</p>	L85s	65-86"	<ul style="list-style-type: none"> <li>• 1320 mm extension</li> <li>• 360° Manual swivel at full extension</li> <li>• Fully extends in 18 – 30 seconds depending on weight load</li> <li>• Quiet operation at 50 dB</li> <li>• Remote control and integration hub included</li> <li>• Easy installation</li> <li>• 79kg weight capacity</li> <li>• 10 Year warranty</li> </ul>	
 <p>STANDARD</p>	XL85	65-86"	<ul style="list-style-type: none"> <li>• 1651 mm extension</li> <li>• Fully extends in 27 – 45 seconds depending on weight load</li> <li>• Quiet operation at 50 dB</li> <li>• Remote control and integration hub included</li> <li>• Easy installation</li> <li>• 79kg weight capacity</li> <li>• 10 Year warranty</li> </ul>	
 <p>MANUAL SWIVEL UNDER FLOOR</p>	XL85s	65-86"	<ul style="list-style-type: none"> <li>• 1651 mm extension</li> <li>• Manual swivel at full extension</li> <li>• Fully extends in 27 – 45 seconds depending on weight load</li> <li>• Quiet operation at just 50 dB</li> <li>• Remote control and integration hub included</li> <li>• Easy installation</li> <li>• 79kg weight capacity</li> <li>• 10 Year warranty</li> </ul>	

# L90 TV POP UP LIFTER

TV Lift For Huge Screens for up to 103" TV

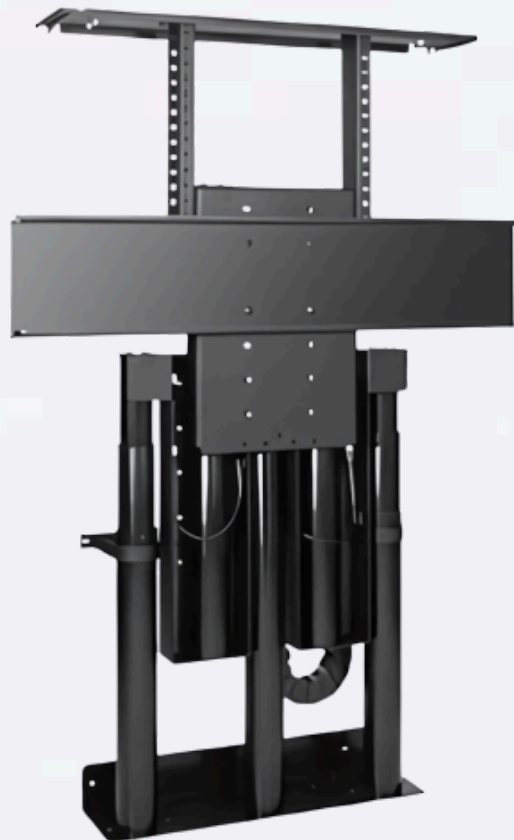

Popular uses: Living rooms, venues and conference-room settings where a large screen is needed.

## Features:

- 90kg weight capacity
- 1270 mm extension
- Fully extends in 17 seconds
- No exposed gears, tracks or scissors
- Quiet operation at 45 dB
- handheld remote control and integration hub included
- Easy installation
- 10 Year warranty

Datasheet











Technical Drawing











# DROP DOWN LIFTERS

## Ceiling Drop Down Solutions

Image	SKU	TV Size	Description	Datasheet
	L77i	Up to 86"	<ul style="list-style-type: none"> <li>• 1320 cm downward travel</li> <li>• 68kg weight capacity</li> <li>• Can be wall mounted</li> <li>• No exposed tracks, gears or scissors</li> <li>• Remote control and integration hub included</li> <li>• 10 Year warranty</li> </ul>	
	L77ix	Up to 86"	<ul style="list-style-type: none"> <li>• 1320mm downward travel</li> <li>• 180° motorized swivel</li> <li>• 68kg weight capacity</li> <li>• No exposed tracks, gears or</li> <li>• Remote control and integration hub included</li> <li>• 10 Year warranty</li> </ul>	
	CL65+	Up to 65"	<ul style="list-style-type: none"> <li>• Tilts 95° downward</li> <li>• Fully extends in 16 seconds</li> <li>• No exposed tracks, gears or scissors</li> <li>• Remote control and integration hub included</li> <li>• 200mm ceiling space required</li> <li>• 45kg weight capacity</li> <li>• 10 Year warranty</li> </ul>	
	CL65e	Up to 65"	<ul style="list-style-type: none"> <li>• When extended bottom edge of TV sits 1473mm from ceiling</li> <li>• Tilts 95° downward</li> <li>• Fully extends in 16 seconds</li> <li>• No exposed tracks, gears or scissors</li> <li>• Remote control and integration hub included</li> <li>• 200mm of ceiling space required</li> <li>• 45kg weight capacity</li> <li>• 10 Year warranty</li> </ul>	

# OTHER LIFTERS

Image	SKU	Weight Rating	Description	Datasheet
	APEX	56kg	<ul style="list-style-type: none"> <li>• Industry Leading Reliability</li> <li>• Easy 3-Step Installation</li> <li>• Ships Fully Assembled</li> <li>• Full Motion</li> <li>• 3 preset positions</li> <li>• Pre installation back box</li> <li>• Remote control and integration hub included</li> <li>• 5 Year warranty</li> </ul>	
	AL250	113kg	<ul style="list-style-type: none"> <li>• 660mm extension</li> <li>• No exposed tracks, gears or scissors</li> <li>• Remote control and integration hub included</li> <li>• 10 Year warranty</li> </ul>	
	AL125	57kg	<ul style="list-style-type: none"> <li>• 660mm extension</li> <li>• No exposed tracks, gears or scissors</li> <li>• Remote control and integration hub included</li> <li>• 10 Year warranty</li> </ul>	
	E550	45kg	<ul style="list-style-type: none"> <li>• Industry-Leading Reliability</li> <li>• Advanced Motorization Technology</li> <li>• Innovative Installation Features</li> <li>• Projector Enclosure</li> <li>• Universal attachment</li> <li>• Remote control and integration hub included</li> <li>• 10 Year warranty</li> </ul>	

# TBMS-MOB-HA-CENT

Mobile Height Adjustable System – Centre Lift



## Features:

- Designed to provide complete flexibility in any learning / presentation area
- Provides inclusive learning for mobility impaired users
- Modular in design, being able to be converted to a Wall Mounted or Free Standing System
- Easy to manoeuvre between areas and pack away when not required
- Sturdy and robust, supporting up to 136kg with simple electronic actuator control
- Central laptop tray included. Webcam and keyboard mounts available
- Integrated power distribution board with surge protection
- Fast and easy installation process, taking under 1 hour
- 5 Year warranty

# TBMS-MOB-HA-A

## Mobile Height Adjustable System – Actuator Lift



### Features:

- Designed to provide complete flexibility in any learning / presentation area
- Provides inclusive learning for mobility impaired users
- Modular in design, being able to be converted to a Wall Mounted or Free Standing System
- Easy to manoeuvre between areas and pack away when not required
- Sturdy and robust, supporting up to 136kg with simple electronic actuator control
- Central laptop tray included. Webcam and keyboard mounts available
- Integrated power distribution board with surge protection
- Fast and easy installation process, taking under 1 hour
- 5 Year warranty

Specification Sheet



# TBMS-FREE-HA-CENT

## Free Standing Height Adjustable System – Centre Lift



### Features:

- Designed to provide complete flexibility in any learning / presentation area
- Provides inclusive learning for mobility impaired users
- Modular in design, being able to be converted to a Wall Mounted or Mobile System
- Free standing design with no need to affix to a wall
- Sturdy and robust, supporting up to 136kg with simple electronic actuator control
- Central laptop tray included. Webcam and keyboard mounts available
- Integrated power distribution board with surge protection
- Fast and easy installation process, taking under 1 hour
- 5 Year warranty

Specification Sheet



# TBMS-FREE-FH-DUAL

## Free Standing Dual Screen System - Fixed Height



### Features:

- Designed to provide complete flexibility in any learning / presentation area
- Modular in design, being able to be converted to a Mobile or Wall Mount Dual Screen System
- Sturdy and robust simple mechanical height adjustability
- Free standing design with no need to affix to a wall
- Central laptop tray and webcam included. Webcam, keyboard and lockable AV cabinet available.
- Integrated power distribution board with surge protection
- Fast and easy installation process, taking under 1 hour
- 5 Year warranty

Specification Sheet



# EST09

## Motorised Up and Down Trolley



### Features:

- Vesa Compatibility: 200 x 200 - 800 x 600mm
- Typical Screen Sizes: 55" - 86"
- Weight Capacity: 100kg's
- Smart Collision Prevention
- 3 Year warranty

Product Specifications



# EST11

## Motorised Height & Tilt Adjustable Trolley



### Features:

- Vesa Compatibility: 200 x 200 - 800 x 600mm
- Typical Screen Sizes: 55" - 86"
- Weight Capacity: 100kg's
- Tilt: 90°
- Smart Collision Prevention
- 3 Year warranty

Datasheet



Specifications



**AV** Supply Group Ltd

# Projection Solutions

**CHIEF® DA-LITE®**

A brand of **legrand®**

A brand of **legrand®**



Explore our professional-grade projection equipment— from compact projectors and ceiling mounts to screens and media control accessories.

Designed for seamless presentations and immersive visual experiences in classrooms, boardrooms, auditoriums, and event venues, these solutions offer crisp image quality and reliable performance. With a focus on integration and ease of use, they deliver the flexibility and clarity your space needs.

# RPM AU

## RPA Elite Universal Projector Mount with Keyed Locking (A version)



### Features:

- Universal Interface Type
- Direct to ceiling or pole mountable
- 3° Roll, 20° Pitch, 360° Yaw and micro-adjustable
- 22.7kg Weight capacity
- UL Listed
- Available in black and white

Installation Manual



Technical Drawing



# VCTUB

## XL Universal Tool-Free Projector Mount



### Features:

- Universal Interface Type
- Direct to ceiling or pole mountable
- 5° Roll, 20° Pitch, 360° Yaw
- 68 kg Weight capacity
- TÜV Certified, UL Listed
- Available in black and white

Installation Manual



Technical Drawing



# MYRIAD SIGHTLINE

## Large Venue Projection Screens



### Myriad Reveal:

- SightLine Cable Drop
- Tensioned with SightLine ①
- Non-Tensioned with SightLine ②
- Standard Black Drop
- Tensioned ③
- Non-Tensioned ④
- Available many different sizes/drops/screen materials

### Myriad Conceal:

- SightLine Cable Drop
- Tensioned with SightLine ⑤
- Non-Tensioned with SightLine ⑥
- Standard Black Drop
- Tensioned ⑦
- Non-Tensioned ⑧
- Available many different sizes/drops/screen materials



# SABLE FRAME 2 SERIES

## Fixed Frame Projection Screens



The Sable Frame 2 from Elite Screens is an entry-level fixed frame screen for today's home cinema projectors. It's easy to assemble and installs in minutes. The black velvet-surfaced 6cm aluminium frame enhances your wall's overall appearance and absorbs projector light overshoot for crisper images.

### Features:

- Diagonal sizes available from 92" - 150" in 16:9 aspect ratio
- Highly versatile CineWhite Gain 1.1 flat tensioned screen material with 160 degree viewing angle
- Black velvet surfaced covered 60mm aluminium frame enhances overall appearance and absorbs projector light overshoot
- Easy to assemble and install in minutes
- Adjustable fix plates provide equal tension over the entire projection surface
- Sliding wall mounts ensure the installation is properly centered
- Compatible with Ultra, Short, and Standard Throw Projectors
- 2-year manufacturer's warranty

User Guide



Brochure



# AEON SERIES

## Edge Free Fixed Frame Projection Screens



The Aeon Series is a fixed frame projection screen that uses Elite's EDGE FREE technology. The EDGE FREE design resembles a giant size flat panel TV display. The Aeon includes velvet tape as an installation option to further enhance the overall appearance.

### Features:

- Diagonal sizes available from 100" - 150" in 16:9 aspect ratio
- Aluminium lightweight split-frame design
- Stretches over frame for a permanent tight-tensioned flat surface
- Easy to assemble and install in minutes
- EDGE FREE or install ultra-thin velvet tape trim
- Wall mount brackets slide ensuring the frame is properly centered
- Optional LED backlight kit with remote control
- 1.1 gain CineWhite (matte white) or 1.2 gain CineGrey 3D
- 2-year Premium Warranty

User Guide



Dimension Table



\*Also available in Acoustically Transparent and Ceiling Light Rejection options

# MANUAL SERIES

## Manual Pull Down Projection Screens



The Manual Series projection screens are the picture perfect solution to a professional projection system for your home, business, or classroom.

### Features:

- Diagonal sizes available from 84" - 150" in 16:9 and 16:10 aspect ratio
- On wall or Ceiling installation
- 180 degree wide viewing angle for commercial presentations or residential home cinema
- Black & White screen housing options
- Auto-locking system provides variable height settings in any position
- Screen lanyard for easy operation included - allows screen's pull down handle to be reached from high areas
- 2-year warranty

\*Also available in Tensioned and Slow Retract options

User Guide



Dimension Table



# SPECTRUM SERIES

## Motorised Projection Screens



The Spectrum series answers the call for a retail electric motorized screen that can be used in either residential or commercial wall/ceiling applications.

### Features:

- Diagonal sizes available 100", 125", 150" & 180" in 16:9 aspect ratio
- On wall or Ceiling installation
- 180 degree wide viewing angle with 1.1 gain
- Black screen housing
- Infrared (IR) remote control
- Detachable 3-way wall UP/STOP/DOWN switch
- Built-in 5-12 volt trigger port enables Drop/Rise operation to synchronize with the projector's power cycle
- Not compatible with Ultra/Short-throw Projectors
- Certified by AMX and CRESTRON
- 2-year warranty

User Guide



Dimension Table



# VMAX2 SERIES

## Motorised Projection Screens



The VMAX 2 Series is an enhanced electric motorized projector screen for commercial and home theatre applications. It has a silent and power-saving synchronous motor.

### Features:

- Diagonal sizes available from 100" - 180" in 16:9 and 16:10 aspect ratio
- On wall or Ceiling installation
- 180 degree wide viewing angle with 1.1 gain
- Black & White screen housing options
- Standard Infrared (IR) and Radio Frequency (RF) remote controls
- Detachable 3-way wall switch
- Built-in 5-12 volt trigger input enables Drop/Rise operation to synchronize with the projector's power cycle
- Not compatible with Ultra/Short-throw Projectors
- Certified by AMX and CRESTRON
- 2-year warranty

User Guide



Brochure



# VMAX SERIES

## Motorised Projection Screens



The VMAX Tab-Tension 3 has a tab-tension design to pull and stretch the surface on all sides to achieve a flat and taut projection surface suitable for ultra, short, and standard throw projectors.

### Features:

- Diagonal sizes available from 100", 120", & 135" in 16:9 aspect ratio
- On wall or Ceiling installation
- Tab-Tensioned for a perfectly flat surface
- 180 degree wide viewing angle with 1.1 gain
- White arc shaped screen housing
- Standard Infrared (IR) and Radio Frequency (RF) remote controls
- Detachable 3-way wall switch
- 5-12 volt trigger input enables Drop/Rise operation to synchronize with the projector's power cycle
- Compatible with Ultra, Short, and Standard Throw Projectors
- ISF Certified for accurate colour reproduction
- 2-year warranty

User Guide



Dimension Table



# EVANESCE SERIES

## Recessed Motorised Projection Screens



The Evanesce B is a versatile in-ceiling projection screen that conveniently disappears from view when not in use. It can be installed from within the above-ceiling airspace or from below thanks to its removable base panels.

### Features:

- Diagonal sizes available are 92", 100", 110" & 120" in 16:9 aspect ratio
- Recessed Ceiling installation
- 180 degree wide viewing angle with 1.1 gain
- Standard Infrared (IR) and Radio Frequency (RF) remote controls
- Detachable 3-way wall switch
- 5-12 volt trigger input enables Drop/Rise operation to synchronize with the projector's power cycle
- ISF Certified for accurate colour reproduction
- 2-year warranty

User Guide



Dimension Table



# EZCINEMA TENSION SERIES

## Portable Projection Screen



The ezCinema Tab-Tension is a free-standing portable projection screen that is offered now with a tab-tension system. It swiftly pulls up and retracts using a scissor-backed free-standing mechanism that requires no extra tools, accessories or effort. This is the perfect 'projector screen in a box' for portable presentations on the go.

### Features:

- Diagonal size of 100" in 16:9 aspect ratio
- MaxWhite 1.1 Gain material with standard black backing is durable and easy to clean
- Easy to transport and set up for traveling
- Features a scissor backed free-standing mechanism for effortless setup
- Solid rotating floor support feet provides added stability
- Wide projection viewing angle with 180 degree diffusion uniformity
- Built-in carrying handle for enhanced mobility and carry case
- Rugged aluminium casing protects the screen
- Compatible with Ultra, Short, and Standard Throw Projectors
- 2-year warranty

User Guide



# YARDMASTER 2 SERIES

## Fast Fold Projection Screens



The Yard Master2 is a folding-frame outdoor projection screen. Its light-weight aluminium frame allows it to be set up in minutes. Simply, unfold the frame; attach the material and legs, then project. The Yard Master2 is the perfect companion for outdoor presentations with front or rear projection materials available.

### Features:

- Diagonal sizes available from 100" - 200" in 16:9 aspect ratio
- CineWhite for front projection / WraithVeil for rear projection
- Black masking borders enhance picture contrast
- Corner pull-tabs make installation easier
- Snap-button attachments on material
- Light-weight aluminium square tube construction
- Single-piece frame system unfolds effortlessly
- Detachable T-legs included
- Assembles in minutes with no tools required
- Soft-padded carrying bag stores entire product for portability
- 2-year warranty

User Guide



Dimension Table



**AV** Supply Group Ltd

# Racking Solutions



**MIDDLE  
ATLANTIC**  
A brand of **legrand**

**SANUS**<sup>®</sup>  
A brand of **legrand**





Discover a range of professional AV racking solutions designed to streamline equipment storage, cooling, and cable management.

From freestanding racks and network enclosures to wall-mounted cabinets and accessories like shelves and fans —these solutions support both standard and custom setups with durability and efficiency in mind.

Ideal for server rooms, control centres, broadcast studios, and education facilities—keep your AV gear secure, accessible, and optimally configured.

# SAFR SERIES

## Component Rack for Home Theatre Equipment

Image	SKU	Specs	Installation Instruction
	SAFR15	<ul style="list-style-type: none"> <li>Rack Space: 15U</li> </ul> Includes: <ul style="list-style-type: none"> <li>1U shelf x 1</li> <li>2U shelf x 1</li> <li>3U shelf x 1</li> <li>1U blanking panel x 1</li> <li>2U blanking panel x 1</li> </ul>	
	SAFR27	<ul style="list-style-type: none"> <li>Rack Space: 27U</li> </ul> Includes: <ul style="list-style-type: none"> <li>1U shelf x 2</li> <li>2U shelf x 2</li> <li>3U shelf x 2</li> <li>1U blanking panel x 2</li> <li>2U blanking panel x 2</li> </ul>	

Comes pre-assembled with blanking panels and vented shelves, quick-release back and side panels for complete and total access to components and wiring. The rack has two 3U cut-out openings on both top and bottom of the rack as well as a removable 3U panel that can be located above or below the rear rack door for added venting or active cooling flexibility. Swivel casters and adjustable feet allow mobility and stable positioning.

### Features:

- Comes pre-assembled
- Cooling system keeps your equipment cool and easily accessible
- Customizable rack to perfectly fit your needs
- Easily access components with removable panels
- Hardware included
- Heavy-gauge steel construction
- Lockable tempered glass doors

# SRSR SERIES

## Slide Out Rack System

Specify an SRSR for easy rear access to equipment connections in millwork, cabinets and flush in-wall installations. Available in 2 useable depths, the SRSR system extends and rotates 90deg in either direction, making it ideal for smaller systems.

Image	SKU	Specs	Installation Instruction
	SRSR-4	<ul style="list-style-type: none"> <li>• Rack Units: 12 -30U options</li> <li>• Usable Depth: 43.82 cm</li> <li>• Usable Height: 53.34 cm</li> <li>• Width: 48.59 cm</li> <li>• Weight Capacity: 113.4kg</li> </ul>	
	SRSR-X	<ul style="list-style-type: none"> <li>• Rack Units: 12 - 30U options</li> <li>• Usable Depth: 53.97 cm</li> <li>• Usable Height: 53.34 cm</li> <li>• Width: 48.59 cm</li> <li>• Weight Capacity: 90.7kg</li> </ul>	

### Features:

- Removable rack frame allows in-shop integration and on-site installation of equipment
- Locks in the extended position for simplified equipment integration
- Rotating equipment bay locks in place at 0o, 60o and 90o for easy installation and servicing
- Self-centering mounting base makes it simple to align system within cabinet opening
- Rear cable support works in conjunction with rear rackrail for effective cable management
- Standard front and rear 10-32 threaded rackrail with marked spaces

# SLIM 5 SERIES

## 19-1/8 Inch Wide Rack Frame



Slim 5 Series rack frame system meets a wide range of project requirements with a strong steel construction and wide open access for easy integration. The Slim 5 Series ships ready-to-assemble.

### Features:

- Lightweight, open design is easy to work with
- Unique interlocking corner joint for exceptional strength and easy assembly
- Optional removable steel side panels and front door on 21/37/43U models
- Top includes two laser knockout locations to mount cooling fans
- Standard front and rear fixed 10-32 threaded rackrails with marked spaces
- Available in 8U to 43U options

Installation Manual



Product Sellsheet



# CFR SERIES

## Stackable Skeleton Rack



SANUS Component Series CFR AV racks can support up to 273kg of AV gear on the floor and up to 90kg when mounted on the wall. The CFR series is a self-aligning rack and can be assembled in just 15 minutes.

### Features:

- Easy to install
- Hardware included
- Mount directly to the wall
- Multiple different height combinations available
- SANUS EcoSystem™-compatible
- Available in 15U and 20U options

Installation Manual



Product Sellsheet



# RACK ACCESSORIES

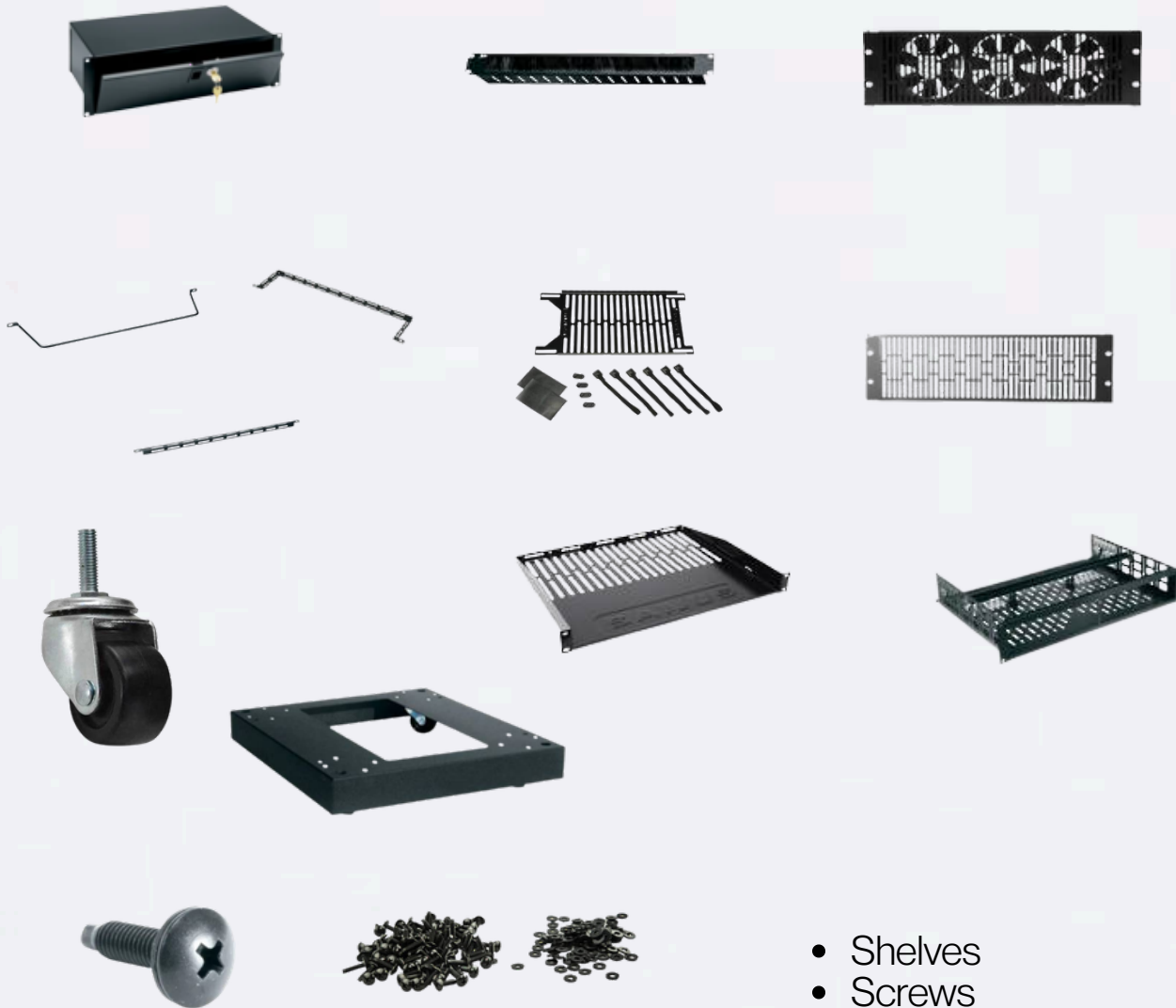

- Shelves
- Screws
- Lacing bars
- Blanking plates
- Cable Management
- Drawers
- Castors
- Side panels
- Front doors

**AV** Supply Group Ltd

# Networking Solutions

# LUXUL®

A brand of  **legrand**®

## Simply Connected.









Explore a curated range of professional network infrastructure products designed to support robust and secure AV installations.

Featuring managed switches, PoE injectors, patch panels, cabling, and wireless access points—these solutions ensure high-speed data, power delivery, and seamless integration for AV devices.

Perfect for corporate, education, and event environments—create dependable network foundations for your AV systems.

# 505 & 515 SERIES

The Luxul 505 & 515 series comprises Layer 2/Layer 3 managed switches equipped with PoE+ and advanced networking capabilities, ideal for applications like AV-over-IP workflows, Dante or AES67 audio, and robust local network setups.





Image	SKU	Datasheet
	SW-505-8P (F/R)	
	SW-505-16P (F/R)	
	SW-505-24P (F/R)	
	SW-515-48P-F (Front facing option only)	

## Features:

- Available in front and rear facing port options
- Layer 2 / Layer 3 Managed Switching
- PoE+ Support with Auto-Recovery
- AV-Over-IP Ready with IGMP snooping and Dante/AES67 support
- Dante and AES67 compatible
- 802.1Q VLAN and QoS support including DCSP
- Remote Management
- Refreshed, simplified UI

# 615 SERIES

The Luxul 615 series is a professional line of Layer 2/Layer 3 managed PoE+ switches built to handle the high demands of AV-over-IP installations and enterprise networks. Available in 24-port and 48-port models, each unit delivers strong PoE budgets alongside four 10 Gb SFP+ uplinks for high-speed backbone connections. With advanced features like VLANs, QoS, IGMP snooping, and static routing, the SW-615 range ensures smooth traffic management and reliable performance. Designed with AV environments in mind, they provide full support for multicast applications as well as Dante and AES67 audio, while intelligent PoE functions such as self-healing and scheduling keep devices running efficiently and with minimal downtime.

Image	SKU	Datasheet
	SW-615-24P (Rear facing only)	
	SW-615-48P (Front facing only)	

## Features:

- 4 × 10 Gb SFP+ uplinks for high-speed backbone connections
- High PoE+ budgets (370 W on 24P, 740 W on 48P)
- Full L2/L3 functionality including VLAN, QoS, ACLs, and static routing
- AV-over-IP ready with IGMP snooping and Dante/AES67 support
- Intelligent PoE management with self-healing and scheduling
- Remote Management
- Refreshed, simplified UI

# ROUTERS & ACCESS POINTS

Image	SKU	Datasheet
	<p>AP-3064</p>	
	<p>XAP-1440</p>	
	<p>XAP-1510</p>	
	<p>XWR-3150</p>	
	<p>XWC-2000</p>	

# CONTACT US

📍 2/6 Ormiston Road, Flat Bush

☎ +64 9 274 9172

✉ info@avsupply.co.nz

🌐 www.avsupply.co.nz

🌐 @avsupplygroupLtd

🌐 @avsupplygroup

